

Power Amp

Drawn by: John Kelley Brown

Title		
Transatlantic Bassman		
Size Custom	Document Number {Doc}	Rev
		A3
Date:	Friday, November 21, 2003	Sheet 2 of 3

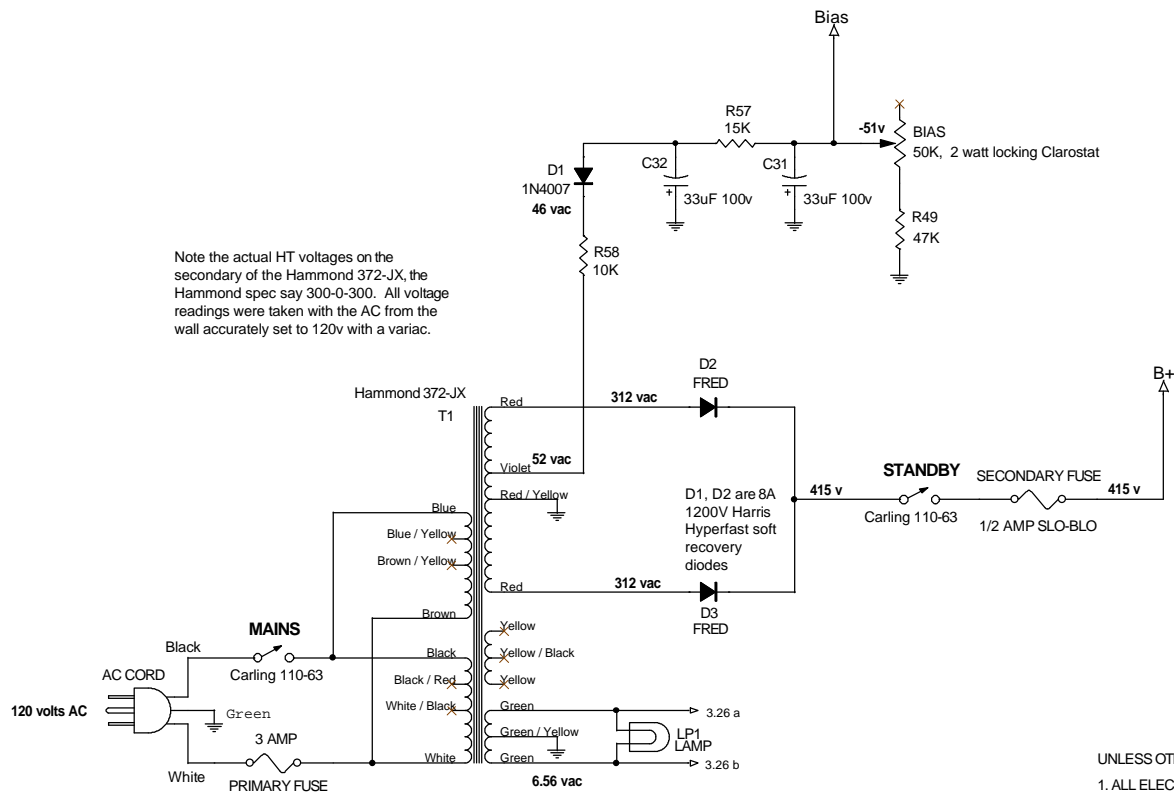

Note the actual HT voltages on the secondary of the Hammond 372-JX, the Hammond spec say 300-0-300. All voltage readings were taken with the AC from the wall accurately set to 120v with a variac.

- UNLESS OTHERWISE SPECIFIED
1. ALL ELECTROLYTIC CAPACITORS ARE MALLORY TC SERIES.
 2. ALL RESISTORS TANTALUM FILM OR KIWAMI, SIGNAL CAPS PAPER-IN-OIL/COPPER FOIL
 3. ALL POTENTIOMETERS ARE 2 WATT AND ARE EITHER CLAROSTAT OR PE.

This amplifier is built into a Fender Bassman head, there was no room for things like Mid knobs, Boost knobs etc. An enhanced version of this schematic will be created that will include these things as well as footswitching channel and boost selection. It will simply be the "Transatlantic".

Power Supply

Drawn by: John Kelley Brown		
Title Transatlantic Bassman		
Size B	Document Number (Doc)	Rev A3
Date: Friday, November 21, 2003	Sheet 3	of 3